



# **MARKSCHEME**

**May 2012**

**COMPUTER SCIENCE**

**Standard Level**

**Paper 1**

13 pages

*This markscheme is **confidential** and for the exclusive use of examiners in this examination session.*

*It is the property of the International Baccalaureate and must **not** be reproduced or distributed to any other person without the authorization of IB Cardiff.*

## General Marking Instructions

*After marking a sufficient number of scripts to become familiar with the markscheme and candidates' responses to all or the majority of questions, Assistant Examiners (AEs) will be contacted by their Team Leader (TL). The purpose of this contact is to discuss the standard of marking, the interpretation of the markscheme and any difficulties with particular questions. It may be necessary to review your initial marking after contacting your TL. **DO NOT BEGIN THE FINAL MARKING OF YOUR SCRIPTS IN RED INK UNTIL YOU RECEIVE NOTIFICATION THAT THE MARKSCHEME IS FINALIZED.** You will be informed by e-mail, fax or post of modifications to the markscheme and should receive these about one week after the date of the examination. If you have not received them within 10 days you should contact your TL and IB Cardiff. Make an allowance for any difference in time zone before calling. **AEs WHO DO NOT COMPLY WITH THESE INSTRUCTIONS MAY NOT BE INVITED TO MARK IN FUTURE SESSIONS.***

You should contact the TL whose name appears on your “Allocation of Schools listing” sheet.

**Note:**

Please use a personal courier service when sending sample materials to TLs unless postal services can be guaranteed. Record the costs on your examiner claim form.

## General Marking Instructions

1. Once markscheme is received mark in pencil until final markscheme is received.
2. Follow the markscheme provided, do **not** use decimals or fractions and mark only in **RED**.
3. Where a mark is awarded, a tick (✓) should be placed in the text at the **precise point** where it becomes clear that the candidate deserves the mark.
4. Sometimes, careful consideration is required to decide whether or not to award a mark. Indeed, another examiner may have arrived at the opposite decision. In these cases write a brief annotation in the **left-hand margin** to explain your decision. You are encouraged to write comments where it helps clarity, especially for moderation and re-marking.
5. Unexplained symbols or personal codes/notations on their own are unacceptable.
6. Record subtotals (where applicable) in the right-hand margin against the part of the answer to which they refer. Show a mark for each part question (a), (b), *etc.* Do **not** circle sub-totals. Circle the total mark for the question in the right-hand margin opposite the last line of the answer.
7. Where an answer to a part question is worth no marks, put a zero in the right-hand margin.
8. **Section A:** Add together the total for the section and write it in the Examiner Column on the cover sheet.  
**Section B:** Record the mark awarded for each of the four questions answered in the Examiner Column on the cover sheet.  
**Total:** Add up the marks awarded and enter this in the box marked TOTAL in the Examiner Column on the cover sheet.
9. After entering the marks on the cover sheet check your addition of all marks to ensure that you have not made an arithmetical error. Check also that you have transferred the marks correctly to the cover sheet. **We have script checking and a note of all clerical errors may be given in feedback to all examiners.**
10. Every page and every question must have an indication that you have marked it. Do this by **writing your initials** on each page where you have made no other mark.
11. A candidate can be penalized if he/she clearly contradicts him/herself within an answer. Once again make a comment to this effect in the left-hand margin.

## Subject Details:            Computer Science SL Paper 1 Markscheme

### Mark Allocation

Section A:    Candidates are required to answer **all** questions. Total 30 marks.

Section B:    Candidates are required to answer **all** questions. Total 40 marks.

Maximum total = 70 marks.

### General

A markscheme often has more specific points worthy of a mark than the total allows. This is intentional. Do not award more than the maximum marks allowed for that part of a question.

When deciding upon alternative answers by candidates to those given in the markscheme, consider the following points:

- Each statement worth one point has a separate line and the end is signified by means of a semi-colon (;).
- An alternative answer or wording is indicated in the markscheme by a “/”; either wording can be accepted.
- Words in ( ... ) in the markscheme are not necessary to gain the mark.
- If the candidate’s answer has the same meaning or can be clearly interpreted as being the same as that in the markscheme then award the mark.
- Mark positively. Give candidates credit for what they have achieved and for what they have got correct, rather than penalizing them for what they have not achieved or what they have got wrong.
- Remember that many candidates are writing in a second language; be forgiving of minor linguistic slips. In this subject effective communication is more important than grammatical accuracy.
- Occasionally, a part of a question may require a calculation whose answer is required for subsequent parts. If an error is made in the first part then it should be penalized. However, if the incorrect answer is used correctly in subsequent parts then **follow through** marks should be awarded. Indicate this with “**FT**”.

**SECTION A****Total: [30 marks]**

1. Early detection of errors in source code through syntax analysis;  
Reusability/portability of programs across different platforms;  
Conversion of source code to executable/object code; **[2 marks]**
  
2. *Award up to [4 marks max].*  
Validation aims to reduce data errors, especially at input stage;  
Data not in a prescribed format for processing are discarded;  
To prevent propagation of invalid data in the system;  
Verification aims to establish the accuracy of the input data;  
And limits errors introduced by human operators in inputting data; **[4 marks]**
  
3. *Award up to [2 marks max].*  
CPU has more primary memory and more registers than a microprocessor;  
CPU stores more programs in ROM than a microprocessor does;  
CPU executes more programs (faster) than a microprocessor;  
Input/output in some microprocessors can be analogue; **[2 marks]**
  
4. To manage the (fair) access to shared resources (processor time, memory, etc.);  
Among several competing processes that run simultaneously;  
To monitor the functioning of hardware resources and report malfunctions; **[2 marks]**
  
5. *Award [1 mark] for each type of data, up to [3 marks max].*  
Normal data and data within the range limits:  
    The system shall correctly work for the correct data as expected;  
  
Extreme data:  
    The system will correctly handle data of correct type, but out of range –  
    error message;  
  
Abnormal Data:  
    The system will handle data of the incorrect type – error message; **[3 marks]**
  
6. *Award [1 mark] for clearing or erasing pre-existing data from the dis. Award up to [2 marks max].*  
An empty file system is set up (or multiple file systems are, if the disk is partitioned);  
A boot sector is installed, with code for booting programs;  
(That are possibly stored elsewhere in the disk;)  
*Accept more detailed descriptions on the role of blocks, block tables, booting sectors, etc.* **[2 marks]**

7. (a)  $2^5 \times 2^5 \times 2^5$  (= 32768); [1 mark]
- (b)  $70 \times 100 \times 2$  Bytes = 14 000 Bytes (or 14 kB, or  $14\,000 \div 1024 = 13.67$  kiB); [1 mark]
- (c) Award [1 mark] for each modality, up to [2 marks max].  
Choose a different colour representation;  
And augment the number of pixels to be stored in 2 bytes;  
  
Resize the initial dimensions;  
To store with the same colour encoding a smaller number of pixels;  
  
Accept bitmap and explanation of how it works.  
Do not accept compression only, without explanations. [2 marks]
8. 8; [1 mark]
9. (a) Award [1 mark] for each part of 4 bits, up to [2 marks max].  
1101 0100 [2 marks]
- (b) 212; [1 mark]
10. Award [1 mark] for describing the role/position of cache;  
Award [1 mark] for how it is used by the CPU;  
Cache between CPU and RAM, temporary store for program instructions, to speed-up retrieval;  
CPU searches an instruction's address first in the cache, and if not found, in RAM; [2 marks]
11. Award up to [1 mark max]. Possible answers include:  
Increased security:  
More expensive to produce, hence risks of forgery is reduced;  
Faster to read/process:  
Understandable by both humans and machines;  
No interpretation needed; [1 mark]

12. Award marks as follows up to **[4 marks max]**.  
Award **[1 mark]** for the disadvantage;  
Award **[1 mark]** for the explanation;  
For **two** cases.

Time consuming;

Because several persons with several roles might be interviewed;

And interviews must target these different categories of people;

Interviewees may talk about about different things, making comparisons difficult;

Answers may not reflect the expectation of persons in roles different from the one of the interviewee;

This can result in contradictory or inconsistent data;

People are often biased/untruthful in interviews;

This can produce incorrect data that can mislead the design team;

Possible not homogeneous interpretations of collected data;

Interviewers might value some details more than others;

**[4 marks]**



**SECTION B**

**Total: [40 marks]**

13. (a) *Award marks as follows up to [5 marks max].  
 Award [1 mark] for showing the mainframe;  
 Award [1 mark] for correct use of switch and possible gateways (to connect LAN to WAN);  
 Award [1 mark] for showing the servers at regional centres;  
 Award [1 mark] for correctly depicting the elements of the LANs;  
 Award [1 mark] for clearly labelling the elements;*

*Several answers are possible: here it is depicted as a star-of-bus. Bus-of-stars (Bus as backbone), star-of-stars (with several switches) and ring-star are viable alternatives.*

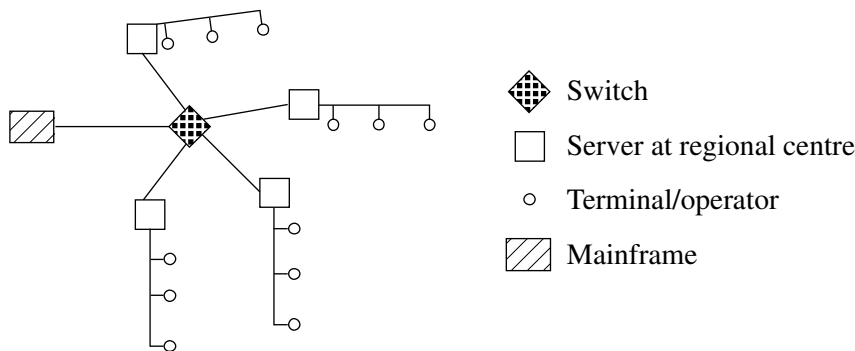

**[5 marks]**

- (b) (i) Optical cable, general telecom lines; **[1 mark]**
- (ii) Twisted pair, coaxial cable;  
*Accept "air" and "Ethernet cable" but do NOT accept "Ethernet" without the "cable" modifier.* **[1 mark]**

- (c) Because a switch inspects the data packet received (destination);  
 It forwards the packet to the appropriate server only;  
 Hence the performances of the network are better than with a hub that would broadcast; **[3 marks]**

**Total: [10 marks]**

14. (a) `sum > capacity;` **[1 mark]**

- (b) *Award marks as follows up to [3 marks max].*  
*Award [1 mark] for a correct b column;*  
*Award [1 mark] for correct columns i and sum;*  
*Award [1 mark] for correct column j;*

b	i	sum	j
{0, 0, 0, 0, 0, 0}	0	3	
{3, 0, 0, 0, 0, 0}	1	10	
{3, 7, 0, 0, 0, 0}	2	11	
{3, 7, 1, 0, 0, 0}	3	13	
{3, 7, 1, 2, 0, 0}	4	22	
{3, 7, 1, 2, 0, 0}			4
{3, 7, 1, 2, 0, 0}			5

**[3 marks]**

- (c) Because the `new` command already initializes all elements of `b` with 0 (default value of `int`); *Must identify a reason (accept “initialized”) not just “because its already all zeros.*

**[1 mark]**

- (d) Parameters `files` and `capacity` such that `files[0] > capacity;`  
*Do not award the mark if there is reference to the variable `sum`.*

**[1 mark]**

- (e) (i) *Award [1 mark] for each situation up to [2 marks max].*  
 An array such that the sum of all its elements is not greater than the capacity;  
 The last existing element will increment the index array for the next iteration, giving an “out of bound” message;

**[2 marks]**

*continued ...*

*Question 14 continued*

- (ii) Award **[1 mark]** for each suggestion up to **[2 marks max]**.
- the **while** must check also the current index of the array;  
(This alone is not sufficient to handle the last element of the array)
  - extend the array files, with one element more (copied into a temporary structure), to correctly perform the comparisons of indexes on the last element;

*Example of working code – (code not required, but some students might return it).*

```
public int[] newcheckcapacity(int[] files, int capacity)
{
    int s = files.length;
    // files is copied into an array having one
    // last element more, set to 0 (default)

    int[] temp = new int[s + 1];
    for (int i = 0; i < s; i = i + 1)
        temp[i] = files[i];

    // the temporary array is used instead of the
    // passed one only to properly handle the indexes
    // in the loop, for the last element

    int[] b = new int[s]; // same length as before
    int sum = temp[0];
    int j = 0;
    while (sum <= capacity && j < s) // new condition
    {
        b[j] = temp[j]; // copy uses temp
        sum = sum + temp[j + 1]; // incremental sum uses temp
        j = j + 1;
    }
    return b;
}
```

**[2 marks]**

**Total: [10 marks]**

15. (a) Card's details (company/number) extracted from chip;  
 Send request of authorization to company transmitting card number, pin, public key and (limit of) 70 EUR and waits for reply message; [2 marks]
- (b) The current expenditure; [1 mark]
- (c) *Award marks as follows up to [4 marks max].*  
*Award [1 mark] for the two inputs (Card and fuel type)*  
*Award [1 mark] for process of calculating bill and producing output;*  
*Award [1 mark] for indicating access/communication to store for update;*  
*Award [1 mark] for returning the card in both failed/success authorization;*  
*Award [1 mark] for dispensing fuel;*  
*Award [1 mark] for card validation/transaction;*

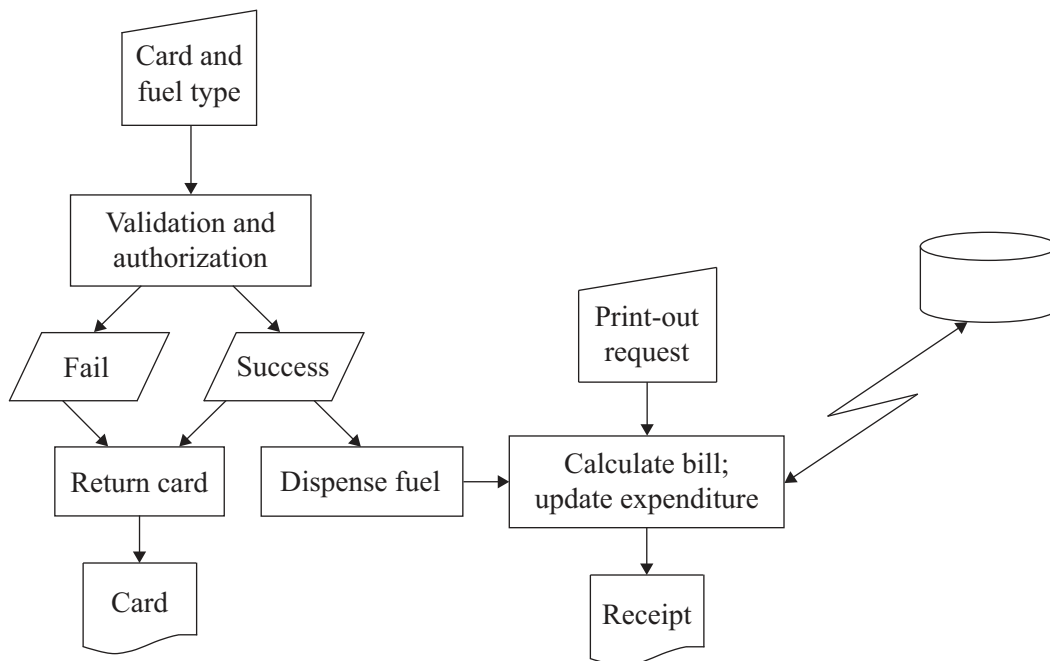

*Different styles for drawing flowcharts are acceptable. Award marks whenever the criteria stated above are clearly visible in the drawing.* [4 marks]

- (d) *Award up to [3 marks max].*  
 If the customer is attacked;  
 A robber can fill his car instead, and also steal the card;  
 But the limit of 70 EUR minimizes the loss for the customer; [3 marks]

**Total: [10 marks]**

16. (a) The update process involves **all** records (linear cost);  
Low processing overhead in using sequential access for a global update; **[2 marks]**
- (b) *Award [1 mark] for any statement such as:*  
Binary search;  
Because the records are ordered; **[2 marks]**
- (c) *Award up to [2 marks max].*  
Open file;  
Find record with binary search using product code;  
When found, compare price with boundaries;  
Close file; **[2 marks]**
- (d) The file needs to be entirely rewritten;  
To maintain the logical order of the record (sequence); **[2 marks]**
- (e) *Award up to [2 marks max].*  
Records placed randomly on disk, directly retrieved via a primary key;  
Access time for a record is constant (fast for interactive processing);  
(and independent from the other records);
- Fully/partially indexed files are not SL, but might be known. Accept these answers.* **[2 marks]**
-